



Ex II 2 G T4

EN  
CE 0353

## 183 RANGE PRESSURE FEED TANKS with and without AGITATION, 9.5, 40 and 60 Litre capacities



**Important: Read and follow all instructions and SAFETY PRECAUTIONS before using this equipment. Retain for future reference.**

### DESCRIPTION

These Pressure Tanks are CE marked in accordance with the Pressure Equipment Directive 97/23/EC and ATEX Directive 94/9/EC Cat 2 G X for use in Zones 1 and 2. The agitators used in the agitated models are ATEX certified to Cat 1/2 Gc T4.

They are suitable for use with flammable materials. 183S models are suitable for use with water based and more corrosive materials.

These pressure tanks are designed as a pressure container to supply liquid material at a constant preset pressure up to a maximum of 7.6 bar (110 psi). The tanks are built to ASME BPV XIII standards. 183G models are constructed from Galvanised carbon steel. 183S models are constructed from stainless steel. A polyethylene liner is included for easy clean up.

Tank Model	Capacity	Material Type	Agitation
183S-210-CE	9.5 litre	Stainless Steel	None
183S-211-CE	9.5 litre	Stainless Steel	Direct Drive
183S-212-CE	9.5 Litre	Stainless Steel	Manual
183S-213-CE	9.5 Litre	Stainless Steel	Gear-reduced (Heavy-duty)
183S-1010-CE	40 litre	Stainless Steel	None
183S-1012-CE	40 litre	Stainless Steel	Manual
183S-1013-CE	40 litre	Stainless Steel	Gear-reduced (Heavy-duty)
183G-1010-CE	40 litre	Galvanised Steel	None
183G-1012-CE	40 litre	Galvanised Steel	Manual
183G-1013-CE	40 litre	Galvanised Steel	Gear-reduced (Heavy-duty)
183S-1510-CE	60 litre	Stainless Steel	None
183S-1512-CE	60 litre	Stainless Steel	Manual
183S-1513-CE	60 litre	Stainless Steel	Gear-reduced (Heavy-duty)

In this part sheet, the words **WARNING**, **CAUTION** and **NOTE** are used to emphasize important safety information as follows:

**WARNING**  
 Hazards or unsafe practices which could result in severe personal injury, death or substantial property damage.

**CAUTION**  
 Hazards or unsafe practices which could result in minor personal injury, product or property damage.

**NOTE**  
 Important installation, operation or maintenance information.

**⚠ WARNING**

**Read the following warnings before using this equipment**



**READ THE MANUAL**

Before operating finishing equipment, read and understand all safety, operation and maintenance information provided in the operation manual.



**READ THE MANUAL**

All personnel must be trained before operating finishing equipment.



**EQUIPMENT MISUSE HAZARD**

Equipment misuse can cause the equipment to rupture, malfunction, or start unexpectedly and result in serious injury.



**DE-ENERGIZE, DEPRESSURIZE, DISCONNECT AND LOCK OUT ALL POWER SOURCES DURING MAINTENANCE**

Failure to De-energize, disconnect and lock out all power supplies before performing equipment maintenance could cause serious injury or death.



**HIGH PRESSURE CONSIDERATION**

High pressure can cause serious injury. Relieve all pressure before servicing. Spray from the spray gun, hose leaks, or ruptured components can inject fluid into your body and cause extremely serious injury.



**PRESSURE RELIEF PROCEDURE**

Always follow the pressure relief procedure in the equipment instruction manual.



**KEEP EQUIPMENT GUARDS IN PLACE**

Do not operate the equipment if the safety devices have been removed.



**AUTOMATIC EQUIPMENT**

Automatic equipment may start suddenly without warning.



**INSPECT THE EQUIPMENT DAILY**

Inspect the equipment for worn or broken parts on a daily basis. Do not operate the equipment if you are uncertain about its condition.



**NEVER MODIFY THE EQUIPMENT**

Do not modify the equipment unless the manufacturer provides written approval.



**KNOW WHERE AND HOW TO SHUT OFF THE EQUIPMENT IN CASE OF AN EMERGENCY**



**STATIC CHARGE**

Fluid may develop a static charge that must be dissipated through proper grounding of the equipment, objects to be sprayed and all other electrically conductive objects in the dispensing area. Improper grounding or sparks can cause a hazardous condition and result in fire, explosion or electric shock and other serious injury.



**WEAR SAFETY GLASSES**

Failure to wear safety glasses with side shields could result in serious eye injury or blindness.



**GET IMMEDIATE MEDICAL ATTENTION**

To prevent contact with the fluid, please note the following:

- a) Never point the gun/valve at anyone or any part of the body.
- b) Never put hand or fingers over the spray tip.
- c) Never attempt to stop or deflect fluid leaks with your hand, body glove or rag.
- d) Always have the tip guard on the spray gun before spraying.
- e) Always ensure that the gun trigger safety operates before spraying.
- f) Always lock the gun trigger safety when you stop spraying



**MEDICAL ALERT**

Any injury caused by high pressure liquid can be serious. If you are injured or even suspect an injury:

- a) Go to an emergency room immediately.
- b) Tell the doctor you suspect an injection injury.
- c) Show the doctor this medical information or the medical alert card provided with your airless spray equipment.
- d) Tell the doctor what kind of fluid you were spraying or dispensing.
- e) Refer to the Material Safety Data Sheet for specific information.



**WEAR RESPIRATOR**

Toxic fumes can cause serious injury or death if inhaled. Wear a respirator as recommended by the fluid and solvent manufacturer's Material Safety Data Sheet.



**TOXIC FLUID & FUMES**

Hazardous fluid or toxic fumes can cause serious injury or death if splashed in the eyes or on the skin, inhaled, injected or swallowed. LEARN and KNOW the specific hazards or the fluids you are using.



**FIRE AND EXPLOSION HAZARD**

Improper equipment grounding, poor ventilation, open flame or sparks can cause hazardous conditions and result in fire or explosion and serious injury.



**PROJECTILE HAZARD**

You may be injured by venting liquids or gases that are released under pressure, or flying debris.



**ELECTRIC SHOCK / GROUNDING**

Improper grounding or sparks can cause a hazardous condition and result in fire, explosion or electric shock and other serious injury.



**PINCH POINT HAZARD**

Moving parts can crush and cut. Pinch points are basically any areas where there are moving parts.



**NOISE HAZARD**

You may be injured by loud noise. Hearing protection may be required when using this equipment.







**PROP 65 WARNING**

WARNING: This product contains chemicals known to the State of California to cause cancer and birth defects or other reproductive harm.

**IT IS THE RESPONSIBILITY OF THE EMPLOYER TO PROVIDE THIS INFORMATION TO THE OPERATOR OF THE EQUIPMENT.**

**FOR FURTHER SAFETY INFORMATION REGARDING BINKS AND DEVILBISS EQUIPMENT, SEE THE GENERAL EQUIPMENT SAFETY BOOKLET (77-5300).**

The following hazards may occur during the normal use of this equipment. Please read the following chart before using the equipment.

HAZARD	CAUSE	SAFEGUARDS
Fire 	Solvents and coatings can be highly flammable or combustible, especially when sprayed.	Adequate exhaust must be provided to keep the air free of accumulations of flammable vapours.  Smoking must never be allowed in the spray area.  Fire extinguishing equipment must be present in the spray area.
Fire- Pressure tank 	Vapours from flammable liquids can catch fire or explode.	Keep tank at least 10 feet away from sources of ignition. Ignition sources include hot objects, mechanical sparks, and arcing (non -explosion proof) electrical equipment.
Explosion Hazard – Pressure Tank – Static Electricity 	Static electricity is created by the flow of fluid through the pressure tank and hose. If all parts are not properly grounded, sparking may occur. Sparks can ignite vapours from solvents and the fluid being sprayed.	Ground the pressure tank by connecting one end of 12 gauge (minimum) ground wire to the pressure tank and the other end to a true earth ground. Local codes may have additional grounding requirements.  See illustration fig 3 on page 7 for grounding and grounding hardware required.
Explosion Hazard – Pressure Tank – Rupture 	Making changes to a pressure tank will weaken it.	Never drill into, weld, or modify the tank in any way.  Do not adjust, remove, or tamper with the safety valve. If replacement is necessary, use the same type and rating of valve.
Explosion Hazard – Galvanized Tanks – Material Compatibility 	Halogenated hydrocarbon solvents – for example 1-1-1 Trichloroethane and methylene chloride – can chemically react with aluminium parts and components and cause an explosion hazard. These solvents will also corrode the galvanized tank coating.	Read the label or data sheet for the material. Do not use materials containing these solvents with galvanized pressure tanks. Stainless steel tank models may be used with halogenated solvents.  Refer to specifications chart to ensure that fluids are chemically compatible with the tank wetted parts. Before placing fluids or solvents in tank, always read accompanying manufacturer’s literature.
General Safety	Improper operation or maintenance may create a hazard.	Operators should be given adequate training in the safe use and maintenance of this equipment. Refer to Pressure Systems Safety Regulations 2000 Approved Code of Practice (UK) or relevant national regulations in the country of use.

## WARNING

High pressure can cause serious injury.

Pressure is maintained in a pressure tank after the system has been shut down.

Always follow this procedure to relieve pressure from the tank.

## PRESSURE RELIEF PROCEDURE

To reduce the risk of injury, follow the pressure relief procedure below

- Before checking or servicing any part of the spray system
  - Before attempting removal of fill port cap or tank cover
  - Whenever the tank is left unattended
1. Turn off the main air supply to the tank.
  2. Close the air inlet valve located on the tank air manifold.
  3. Bleed off air in the tank by turning the air relief valve (5) thumb screw counter clockwise. Wait until all the air has escaped through the valve before removing the pressure tank cover or fill port cap.
  4. Leave the air relief valve open until you have reinstalled the tank cover or fill port cap.

## SPECIFICATIONS

	183G GALVANIZED TANKS	183S STAINLESS STEEL TANKS
Maximum Working Pressure	110 psi	
Tank Shell	SA-414 Steel, Galvanized (Zinc)	304 Stainless Steel
Tank Lid	SA-414 Steel, Galvanized (Zinc)	304 Stainless Steel
Fluid Tube	3/8 in. Steel Pipe, Galvanized	3/8 in. SS Pipe, 316 Stainless Steel
Fluid Outlet (Elbow)	Steel, Zinc Plate	316 Stainless Steel
Fluid Valve, Outlet	Brass, Nickel Plate 3/8-18 NPS(M)	316 Stainless Steel 3/8-18 NPS(M)
Agitator Paddle/Propeller	Conductive Nylon, Glass Filled	
Agitator Shaft	303 Stainless Steel	
Agitator Shaft Seal	Engineered PTFE, Stainless Steel	
Air Manifold	Steel, Zinc Plate	
Plug (Air Manifold Coupling)	Steel, Zinc Plate	18-8 Stainless Steel
Bottom Outlet (Optional Kit)	304 Stainless Steel 3/4-14 NPS(M)	

## AGITATION OPTIONS

Type	Application
No Agitation	Materials that require minimal or no mixing and/or readily hold any solids in suspension.
Direct Drive Agitation	Low to medium viscosity materials that require mixing and/or solids suspension.
Gear-reduced Drive Agitation	Heavy-duty agitator for medium to high viscosity materials that require mixing and/or solids suspension.

**WARNING**

**High pressure can cause serious injury.**

**Pressure is maintained in a pressure tank after the system has been shut down.**

**Follow the pressure-relief procedure on page 3 before opening the lid or fill port or performing maintenance on the tank.**

**INSTALLATION**

**Regulator Assembly**

1. Unbox the regulator assembly and mount it on the manifold connection with the swivel connection .
2. If BSP thread is required, attach adaptors to the ball valve fluid outlet ball valve and the air inlet/outlet connections on the regulator.
3. For agitator models, connect the air hose from the adjusting valve on the drive motor to the swivel elbow on the regulator.

**Air Supply**

1. The air supply line should pass through an air filter/regulator to filter dirt from air and remove entrained water and oil. Connect the air supply hose to the air inlet fitting on tank regulator. Connect the atomisation air hose to the air outlet fitting which is directly opposite air inlet fitting.
2. Connect material hose to the fluid outlet ball valve.
3. See Figure 1 below for a typical installation.

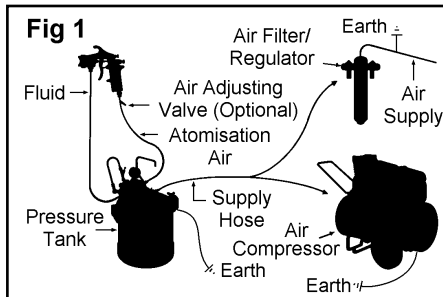

4. To avoid hazards from electrostatic discharges, the tank should be earthed directly via an earth clamp. There is an earth connection point on the lower part of the tank shell. See p7 for connection diagram. Air supply hoses should be conductive to avoid creating electro static

charges. Check continuity to earth before using the equipment.

**LUBRICATION – Agitated Models**

1. An automatic air line filter/lubricator should be installed in the air supply line no more than 0.5m from the air motor. The filter should be 5 micron. Install the lubricator level with or above the motor so the oil mist will blow directly into or down into the motor (see Fig. 2).
2. Fill the oil reservoir with SAE 10W motor oil. Adjust lubricator to feed 1 drop of oil for every 1400 litres (50 cfm) of air or 1 drop per minute for continuous running.

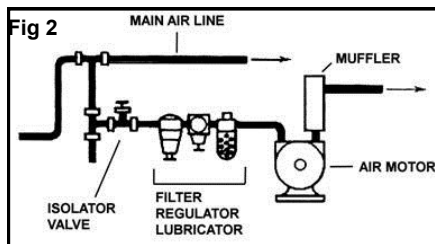

**PREPARATION**

Mix and prepare material to be used according to manufacturer’s instructions. Strain material through a fine mesh screen to remove lumps, skin, and foreign matter that might enter and clog fluid passages and/or spray equipment.

Follow pressure relief procedure on page 3..

To add material to the tank, remove the lid and pour directly into the tank or container.

Replace the lid assembly and tighten thumb screws securely.

Connect the material hose to the fluid outlet ball valve.

**OPERATION**

1. Close the air inlet valve to tank. Turn handle on regulator counter clockwise until spring tension is relieved.
2. Turn on air supply to the tank.
3. Open the air inlet valve to the tank.
4. Open the fluid outlet valve.
5. Turn handle on tank pressure regulator clockwise to pressurize tank.
6. Turn on atomization air to spray gun at source of supply.
7. Test spray. For further instructions consult literature provided with spray gun.
8. If an air motor driven agitator is used,

start the agitator by slowly opening up the needle valve. Air motor speed should be regulated according to the nature of the material being agitated.

**MAINTENANCE**

To clean equipment, proceed as follows:

1. Turn off the air supply.
2. Follow the pressure relief procedure.
3. Turn T-handle adjusting screw on tank fluid pressure regulator counter clockwise until no spring pressure is felt.
4. Loosen thumb screws (17), tip clamps (16) back and tip lid (11) to one side of tank. Do not remove lid from tank.
5. To drain down the fluid supply hose to the gun, remove the Aircap and replace with about 2 turns. Trigger the spaygun into the booth , which will create a back pressure in the fluid line and force the fluid back into the tank.
6. Now remove the lid, empty and clean the parts that have come into contact with the material with compatible cleaning material.
7. When clean, pour a little cleaning material into the tank and replace the lid.
8. Repeat 1 to 5 of the **OPERATION**.
9. Do not turn on the atomising air to the Gun. Make sure the Aircap is fully tight. Trigger the gun and jet the cleaning material into a container until clean material is visible.
10. Remove solvent and replenish with new material as from **INSTALLTION** section 1 onwards.

**LUBRICATION – Agitated Models**

Refer to the service manual SBBI-E-19-095 provided with the air motor for lubrication information.

The bearings in the agitator bearing assembly are impregnated with special non-gumming oil. Additional lubrication is not required.

The agitator shaft seal does not require lubrication.

**PREVENTATIVE MAINTENANCE**

1. Keep the safety valve clean at all times. Check regularly by pulling the ring to ensure the valve is free to operate.

## SERVICE CHECKS

FAULT CONDITION	CAUSE	CORRECTION
Air escaping from port on regulator cap.	Broken or damaged diaphragm	Replace diaphragm.
Pressure creepage registered on gauge.	Dirty or worn valve seat in regulator.	Clean or replace valve seat.
Material tends to settle out rapidly.	Not enough agitation of material.	Increase agitation.
Air leakage at agitator seal.	Defective seal assembly.	Replace.
Paint getting into bearing assembly of agitator.	Paint level in tank too high. Defective agitator shaft seal.	Keep fluid level under bearing ass'y. Replace.
Fluid or air leak at lid gasket.	Thumb screw not tight. Defective lid gasket.	Tighten. Replace.
Fluid or air leak at fill port gasket.	Fill port cap not tight. Defective fill port gasket.	Tighten fluid tube into lid. Reduce speed of agitator.
Air mixing with paint	Fluid tube not sealed to lid. Excessive agitation.	Tighten fluid tube into lid. Reduce speed of agitator.

**FOR FURTHER SAFETY INFORMATION REGARDING BINKS AND DEVILBISS EQUIPMENT, SEE THE  
GENERAL EQUIPMENT SAFETY BOOKLET (77-5300).**

## 183S RANGE - 9.5 LITRE TANK ASSEMBLIES

**Note**

Use PTFE based thread sealant on all air and fluid connections



For regulator parts see page 13

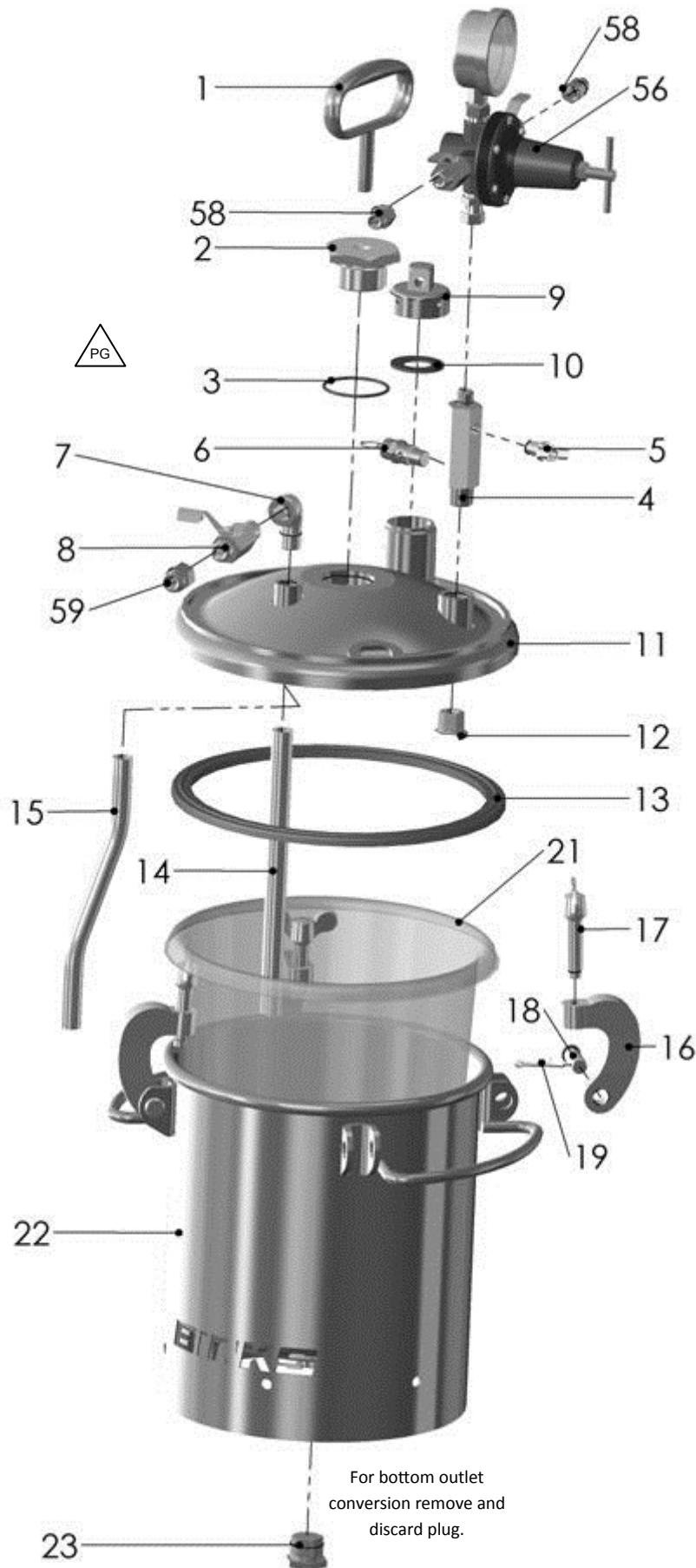

### DIRECT DRIVE AGITATOR

For regulator parts  
see page 13

△ PG	PETROLEUM JELLY/GREASE
---------	---------------------------

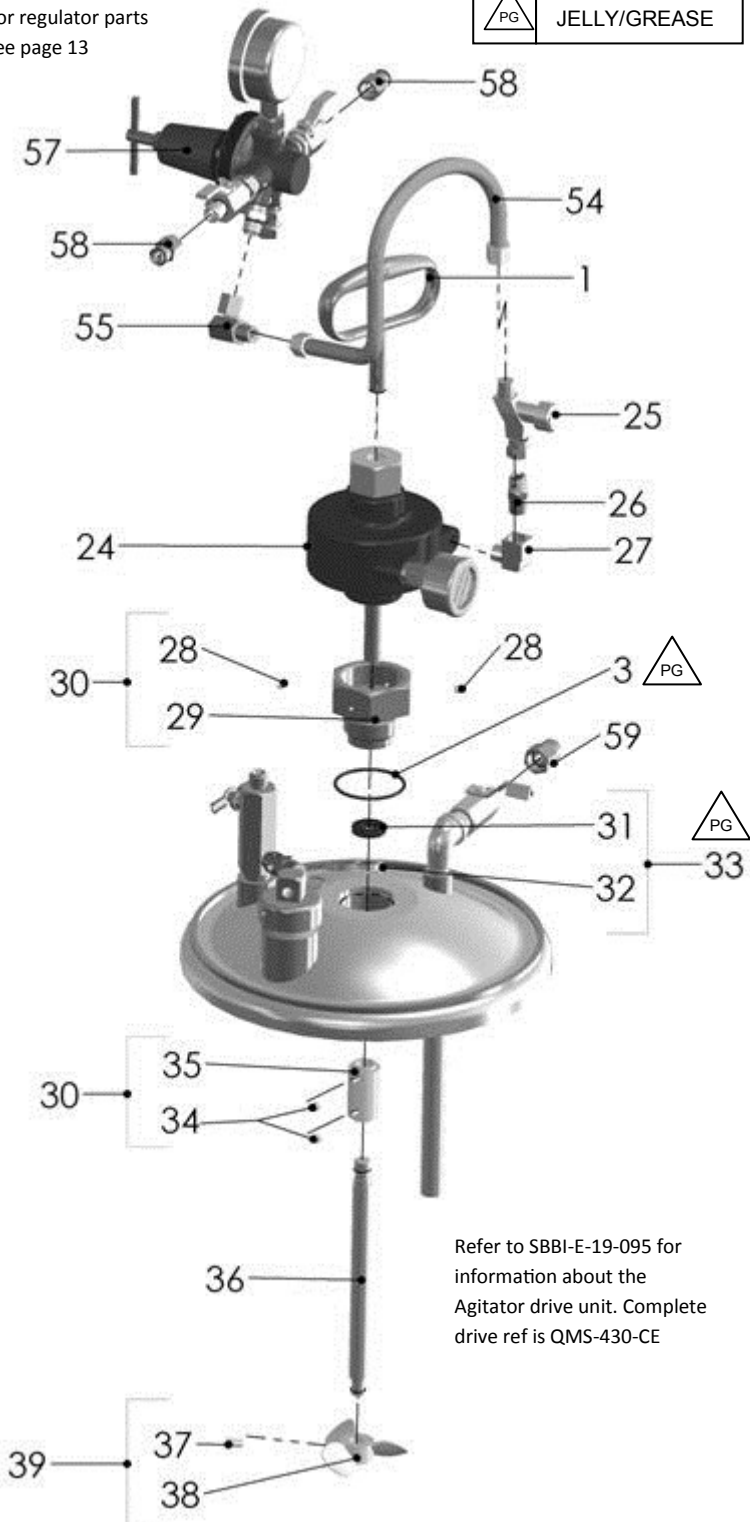

Refer to SBBI-E-19-095 for information about the Agitator drive unit. Complete drive ref is QMS-430-CE

**Note**  
Open side of shaft seal (31) faces downwards.

Retainer (32) required only for vacuum operation.

### DIRECT DRIVE AGITATOR-REGULATOR HOOK-UP



#### Grounding Diagram

Purchase hardware locally

5/16-18 x 3/4 Long  
Hex Head Bolt  
(1 Required)

5/16-18 Hex Head Nut  
(2 Required)

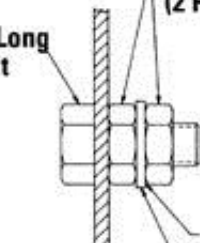

Sufficient Length  
12 Gauge Wire  
(Not Shown)  
5/16 Lock Washer  
(1 Required)  
Tank Skirt (Ref)

FIG 3



### GEAR-REDUCED AGITATOR

**Note**

Use PTFE based thread sealant on all air and fluid connections

For regulator parts see page 13

PG	PETROLEUM JELLY/GREASE
----	---------------------------

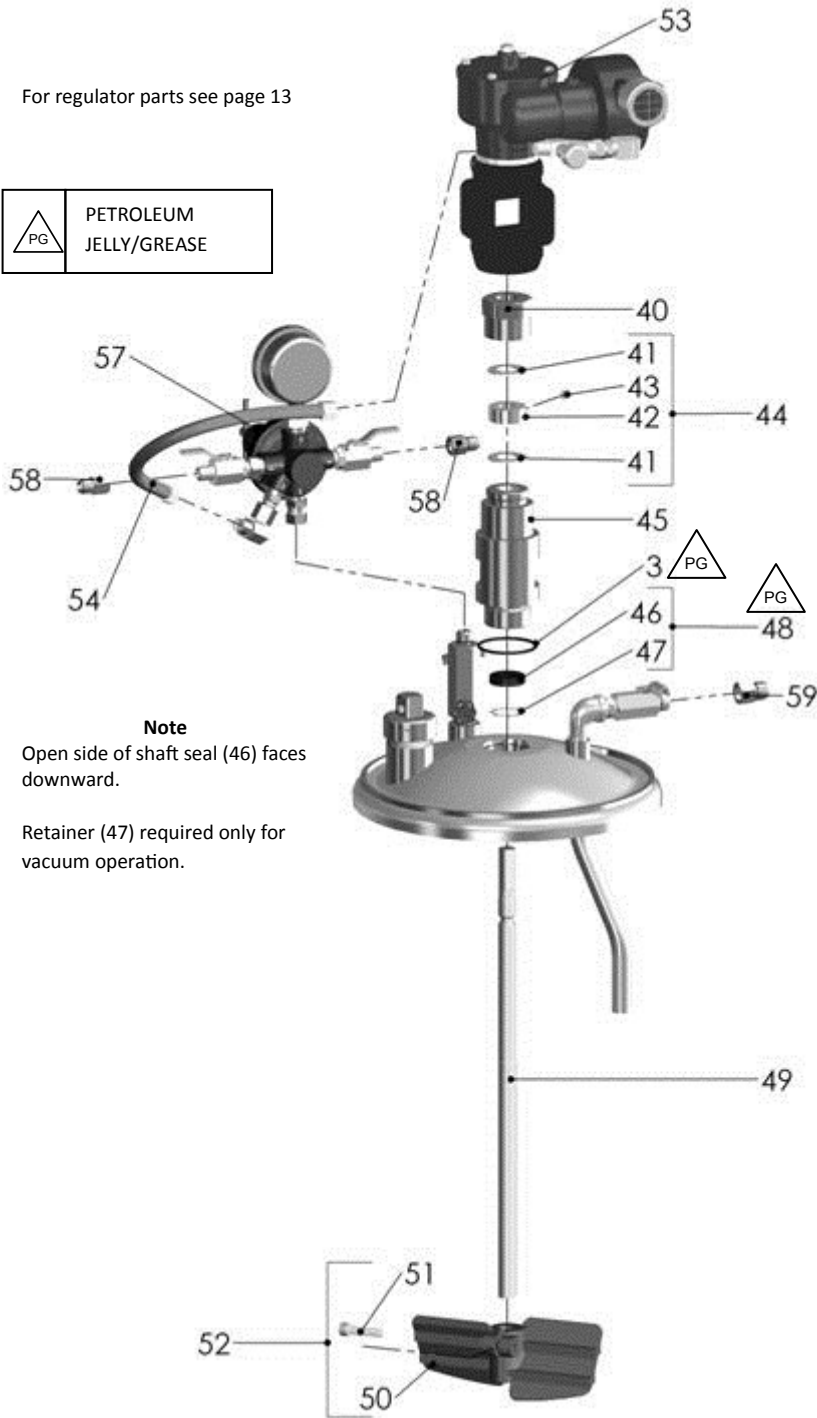

**Note**

Open side of shaft seal (46) faces downward.

Retainer (47) required only for vacuum operation.

### GEAR-REDUCED DRIVE AGITATOR-REGULATOR HOOK-UP



Refer to SBBI-E-19-095 for information about maintenance of the agitator assembly. Agitator ref is QMS-431-CE, Drive motor QS-5012-CE



## PARTS LIST—183S RANGE 9.5 LITRE STAINLESS STEEL TANK ASSEMBLIES

ITEM	PART NO.	DESCRIPTION	83S-210-CE	83S-211-CE	83S-213-CE
			QTY	QTY	QTY
1	QN-97	HANDLE	1	----	----
2	QMS-2	PLUG (NON-AGITATED MODELS ONLY)	1	----	----
3	SSG-8184-K2	O-RING (KIT OF 2)	1	1	1
4	QMG-21	AIR MANIFOLD	1	1	1
5	SS-2707	AIR RELIEF VALVE 1/4 NPT-M	1	1	1
6	TIA-4110-CE	SAFETY VALVE ASSY, 110 PSI	1	1	1
7	• SSP-1939 (S.S.)	STR ELBOW (3/8-18)	1	1	1
8	VA-527	BALL VALVE 3/8 NPS OUTLET	1	1	1
9	83-524-K	FILL PORT CAP (INCL ITEM 10)	1	1	1
10	83-1207-K5	FILL PORT CAP GASKET (QTY PACK)	1	1	1
11	QMS-416-1	TANK LID	1	1	1
12	20-6858	PLUG (1/2-14)	1	1	1
13	QMS-80-1	TANK GASKET 2 GAL	1	1	1
14	QMS-9-1	FLUID TUBE (DIR DRIVE AGIT)	1	1	----
15	QMS-53-1	FLUID TUBE (GEAR REDUCED AGIT)	----	----	1
16	QMG-43-CE	CLAMP (SEE ITEM 20)	4	4	4
17	QMG-46-CE	THUMBSCREW (SEE ITEM 20)	4	4	4
18	QMG-40-CE	CLEVIS PIN (SEE ITEM 20)	4	4	4
19	SSN-2404-ZN	COTTER PIN, 1/8 DIA. X 1" LG. (SEE ITEM 20)	4	4	4
21	PT-78-K10, K60	DISPOSABLE TANK LINER (10 OR 60 EACH)	1	1	1
22	QMS-502-1	TANK & LUG ASSY	1	1	1
23	----	BOTTOM PLUG	1	1	1
24	QMS-428	AIR MOTOR ASSY	----	1	----
25	HAV-500-B	AIR ADJUSTING VALVE	----	1	----
26	H-2008	NIPPLE 1/4 NPS x 1/4 NPT	----	1	----
27	• ----	STREET ELBOW (1/4-18 NPT, BRASS)	----	1	----
28	----	SET SCREW (1/4-20 X 1/4)	----	2	----
29	# ----	ADAPTER (SEE ITEM 30)	----	1	----
30	KK-4991	SEAL RETAINER KIT (INCL 28, 29, 34,35)	----	1	----
31	----	SHAFT SEAL 1/2 I.D. (DIR. DRIVE AGIT)	----	1	----
32	----	INTERNAL RETAINING RING (DIR. DRIVE AGIT)	----	1	----
33	KK-5041	SHAFT SEAL KIT (DIR. DRIVE AGIT)	----	1	----
34	• ----	SET SCREW (1/4-20 X 1/4) S.S.	----	2	----
35	# ----	SHAFT COUPLING (SEE ITEM 30)	----	1	----
36	QMS-73	AGITATOR SHAFT	----	1	----
37	• ----	SQ HD SET SCREW, 1/4-20 X 3/8, S.S.	----	1	----
38	----	PROPELLOR	----	1	----
39	QMS-448-CE	AGITATOR PROPELLER KIT (DIR. DRIVE)	----	1	----
40	QMS-46	RETAINING NUT	----	----	1
41	KK-5049	THRUST WASHER (KIT OF 2/EA)	----	----	1
42	----	THRUST COLLAR	----	----	1
43	• ----	SET SCREW, 5/16-18 X 3/8	----	----	1
44	QMS-447	THRUST COLLAR KIT (INCL. 42 and 43)	----	----	1
45	QMS-407	BEARING ASSY.	----	----	1
46	----	SHAFT SEAL 5/8 I.D. (GEAR REDUCED AGIT)	----	----	1
47	----	INTERNAL RETAINING RING (GEAR REDUCED AGIT)	----	----	1
48	KK-5042	SHAFT SEAL KIT (GEAR REDUCED AGIT)	----	----	1
49	QMS-5	AGITATOR SHAFT	----	----	1
50	----	AGITATOR PADDLE	----	----	1
51	----	SOC HD CAP SCREW, 5/16-18 X 1-1/4, S.S.	----	----	1
52	QMS-449-CE	AGITATOR PADDLE KIT (INCL 51 AND 52)	----	----	1
53	QS-5012-CE	AIR MOTOR/GEARBOX DRIVE	----	----	1
54	HA-57011	AIR HOSE ASSY	----	----	1
55	SSP-30-ZN	SWIVEL ELBOW	----	----	1
56	85-470	AIR CONTROL (NON-AGITATOR TANKS)	1	----	----
57	85-471	AIR CONTROL (AGITATOR TANKS)	----	1	1
58	¶ CT-453	ADAPTOR 1/4" BSP (M) - 1/4" NPS (F)	2	2	2
59	¶ CT-454	ADAPTOR 3/8" BSP (M) - 3/8" NPS (F)	1	1	1

¶ BSP MODELS ONLY • Purchase locally

## 183S & G, 40 AND 60 LITRE TANK ASSEMBLIES

For regulator parts see page 13

**Note**

Open side of shaft seal (8) faces downward.

Retainer (9) required only for vacuum operation.

Refer to SBBI-E-19-095 for information about the Agitator drive unit, ref QS-5012-CE. Complete drive ref is QMS-433-CE (40L) and QMS-434-CE (60L)

Agitator-Regulator Hook-Up with Standard Regulation.

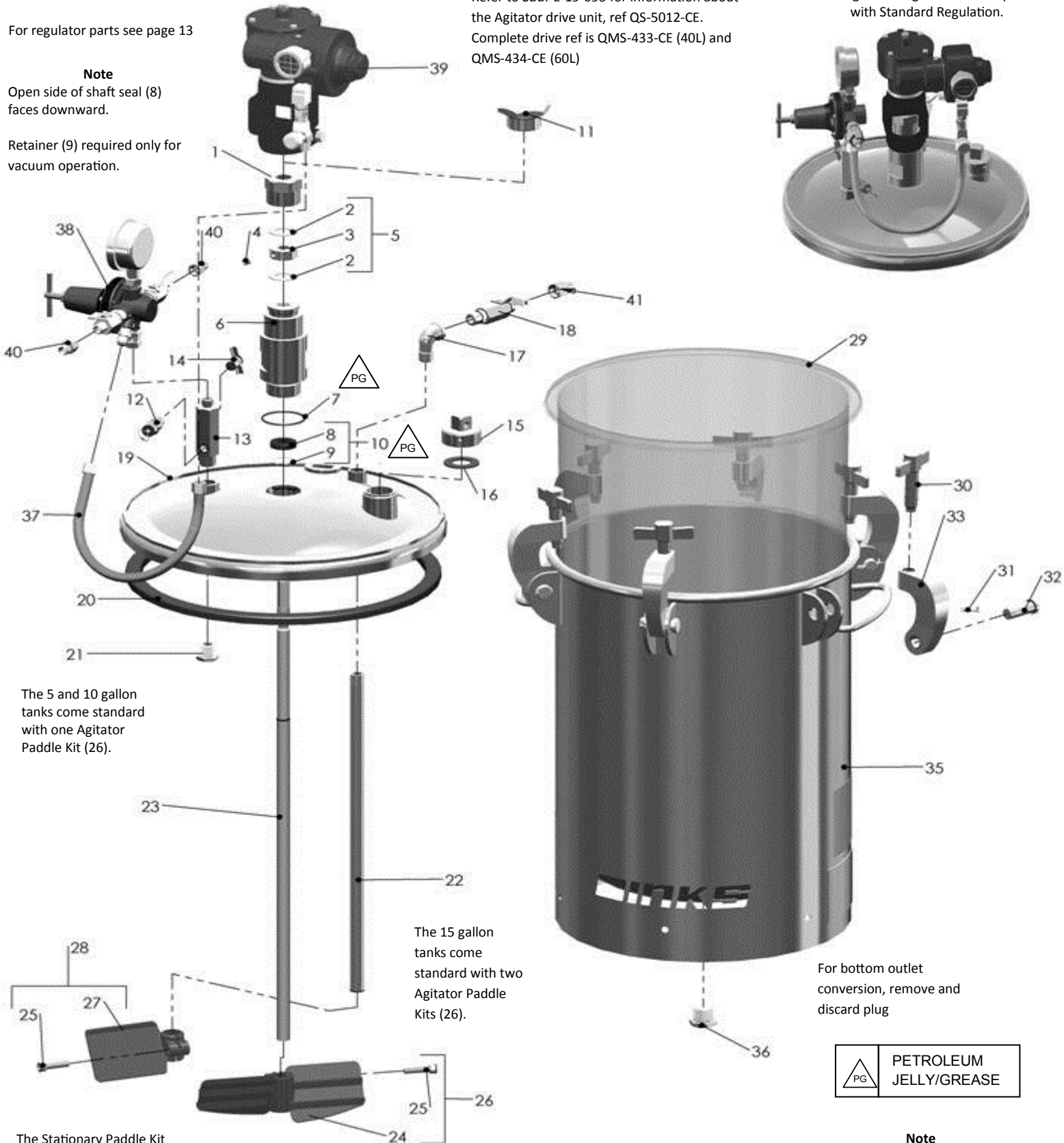

The 5 and 10 gallon tanks come standard with one Agitator Paddle Kit (26).

The 15 gallon tanks come standard with two Agitator Paddle Kits (26).

The Stationary Paddle Kit (28) comes standard only on 10 and 15 gallon tanks.

For bottom outlet conversion, remove and discard plug

PG	PETROLEUM JELLY/GREASE
----	------------------------

**Note**  
Use PTFE based thread sealant on all air and fluid connections



**PARTS LIST - 183S - 40 AND 60 LITRE STAINLESS STEEL TANK ASSEMBLIES**

ITEM	PART NO.	DESCRIPTION	183S-1010	183S-1013	183S-1510	183S-1513
			QTY	QTY	QTY	QTY
1	QMS-46	RETAINING NUT	----	1	----	1
2	QMG-85	THRUST WASHER	----	2	----	2
3	----	THRUST COLLAR	----	1	----	1
4	• ----	SET SCREW (5/16-18 X 3/8)	----	1	----	1
5	QMS-447	THRUST COLLAR KIT (INCL 4 & 5)	----	1	----	1
6	QMS-407	BEARING ASSY-PLAIN STEEL	----	1	----	1
7	SSG-8184-K2	O-RING (KIT OF 2)	1	1	1	1
8	----	SHAFT SEAL 5/8 I.D.	----	1	----	1
9	----	INTERNAL RETAINING RING	----	1	----	1
10	KK-5042	SHAFT SEAL KIT (INCL 8 & 9)	----	1	----	1
11	QMS-3	PLUG (NON-AGITATED MODELS ONLY)	1	----	1	----
12	TIA-4110-CE	SAFETY VALVE ASSY, 110 PSI	1	1	1	1
13	QMG-21	AIR MANIFOLD	1	1	1	1
14	SS-2707	AIR RELIEF VALVE 1/4 NPT(M)	1	1	1	1
15	83-524-K	FILL PORT CAP (INCL ITEM 16)	1	1	1	1
16	83-1207-K5	FILL PORT CAP GASKET	1	1	1	1
17	SSP-1939	STREET ELBOW, 3/8-18 NPT, S.S.	1	1	1	1
18	VA-527	BALL VALVE, 3/8 NPS OUTLET, S.S.	1	1	1	1
19	QMS-417-1	TANK LID	1	1	1	1
20	QM-1458-1	TANK GASKET	1	1	1	1
21	• ----	PLUG, 1/2-14 NPT, S.S.	1	1	1	1
22	QMS-11-1	FLUID TUBE	1	1	----	----
22	QMS-12-1	FLUID TUBE	----	----	1	1
23	QMS-7	AGITATOR SHAFT	----	1	----	----
23	QMS-8	AGITATOR SHAFT	----	----	----	1
24	----	AGITATOR PADDLE	----	1	----	2
25	• ----	SOC HEAD CAP SCREW, 5/16-18 X 1-1/4, S.S.	----	2	----	3
26	QMS-444-CE	AGITATOR PADDLE KIT (INCL 24 & 25)	----	1	----	2
27	----	STATIONARY PADDLE	----	1	----	1
28	QMS-445-CE	STATIONARY PADDLE KIT (INCL 25 & 27)	----	1	----	1
29	PTL-412-K8	DISPOSABLE TANK LINER, 10-GAL	----	1	----	----
29	PTL-415-K10	DISPOSABLE TANK LINER, 15-GAL	----	----	----	1
30	QM-1352-CE	THUMB SCREW (SEE ITEM 34)	6	6	6	6
31	• SSN-2404-ZN	COTTER PIN, 1/8 DIA. X 1" LG. (SEE ITEM 34)	6	6	6	6
32	QMG-38-CE	CLEVIS PIN (SEE ITEM 34)	6	6	6	6
33	QMG-9-CE	CLAMP (SEE ITEM 34)	6	6	6	6
35	QMS-510-1	TANK & LUG ASSY, 10-GAL	----	1	----	----
35	QMS-515-1	TANK & LUG ASSY, 15-GAL	----	----	----	1
36	----	BOTTOM PLUG	1	1	1	1
37	HA-57011	AIR HOSE ASS'Y (INCL W/ ITEM 39)	----	1	----	1
38	85-470	AIR CONTROL—NON AGITATED TANKS	1	----	1	----
38	85-471	AIR CONTROL—WITH AGITATORS	----	1	----	1
39	QS-5012-CE	AIR MOTOR/GEARBOX DRIVE	----	1	----	1
40	¶ CT-453	ADAPTOR 1/4" BSP (M) - 1/4" NPS (F)	2	2	2	2
41	¶ CT-454	ADAPTOR 3/8" BSP (M) - 3/8" NPS (F)	1	1	1	1

¶ BSP MODELS ONLY • Purchase locally



**PARTS LIST - 183G - 40 LITRE GALVANIZED STEEL TANK ASSEMBLIES**

ITEM	PART NO.	DESCRIPTION	183G-1010	183G-1013
			QTY	QTY
1	QMS-46	RETAINING NUT	----	1
2	QMG-85	THRUST WASHER	----	2
3	----	THRUST COLLAR	----	1
4	• ----	SET SCREW (5/16-18 X 3/8)	----	1
5	QMS-447	THRUST COLLAR KIT (INCL 4 & 5)	----	1
6	QMG-409	BEARING ASSY-PLAIN STEEL	----	1
7	SSG-8184-K2	O-RING (KIT OF 2)	1	1
8	----	SHAFT SEAL 5/8 I.D.	----	1
9	----	INTERNAL RETAINING RING	----	1
10	KK-5042	SHAFT SEAL KIT (INCL 8 & 9)	----	1
11	QMG-19	PLUG (NON-AGITATED MODELS ONLY)	1	----
12	TIA-4110-CE	SAFETY VALVE ASSY, 110 PSI	1	1
13	QMG-21	AIR MANIFOLD	1	1
14	SS-2707	AIR RELIEF VALVE 1/4 NPT(M)	1	1
15	83-524-K	FILL PORT CAP (INCL ITEM 16)	1	1
16	83-1207-K5	FILL PORT CAP GASKET	1	1
17	• ----	STREET ELBOW, 3/8-18 NPT (Brass)	1	1
18	VA-540	BALL VALVE, 3/8 NPS OUTLET	1	1
19	QMG-402-1	TANK LID	1	1
20	QM-1458-1	TANK GASKET	1	1
21	• ----	PLUG, 1/2-14 NPT (PLATED STEEL)	1	1
22	QMG-33	FLUID TUBE	1	----
23	QMG-29	AGITATOR SHAFT	----	1
24	----	AGITATOR PADDLE	----	2
25	• ----	SOC HEAD CAP SCREW, 5/16-18 X 1-1/4, S.S.	----	3
26	QMS-444-CE	AGITATOR PADDLE KIT (INCL 24 & 25)	----	2
27	----	STATIONARY PADDLE	----	1
28	QMS-445-CE	STATIONARY PADDLE KIT (INCL 25 & 27)	----	1
29	PTL-412-K8	DISPOSABLE TANK LINER, 10-GAL	1	----
30	QM-1352	THUMB SCREW (SEE ITEM 34)	6	6
31	• SSN-2404-ZN	COTTER PIN, 1/8 DIA. X 1" LG. (SEE ITEM 34)	6	6
32	QMG-38-CE	CLEVIS PIN (SEE ITEM 34)	6	6
33	QMG-9-CE	CLAMP (SEE ITEM 34)	6	6
35	QMG-510-1	TANK & LUG ASSY, 10-GAL	1	----
36	----	BOTTOM PLUG	1	1
37	HA-57011	AIR HOSE ASS'Y (INCL W/ ITEM 39)	----	1
38	85-470	AIR CONTROL—NON AGITATED TANKS	1	----
38	85-471	AIR CONTROL—WITH AGITATORS	----	1
39	QS-5012-CE	AIR MOTOR/GEARBOX DRIVE	----	1
40	¶ CT-453	ADAPTOR 1/4" BSP (M) - 1/4" NPS (F)	2	2
41	¶ CT-454	ADAPTOR 3/8" BSP (M) - 3/8" NPS (F)	1	1

¶ BSP MODELS ONLY      • Purchase locally

## SINGLE REGULATOR AIR CONTROL

85-470 for non-agitated tanks  
85-471 for agitated tanks

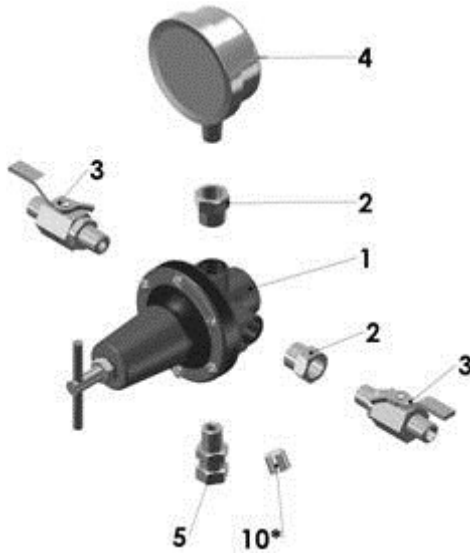

Single Regulator Air Control 85-470 and 85-471

ITEM	PART NO.	DESCRIPTION	85-470	85-471
1	§ HAR-511	AIR REGULATOR	1	1
2	• -----	BUSHING-STL-PLTD- 3/8 (m) x 1/4 (f)	2	2
3	VA-542	BALL VALVE	2	2
4	83-1290	GAUGE - 150 PSI	1	1
5	SSP-8217-ZN	SWIVEL ADAPTER	1	1
6	• -----	1/4 NPT PLUG (SUPPLIED W/ REGULATOR)	1	---
10	H-2008	NIPPLE 1/4 NPS x 1/4 NPT SWIVEL ELBOW - 1/4 NPS(m) x	---	1
11	SSP-30-ZN	1/4 NPS (sw)	---	1
• Purchase locally				
§ Refer to 77-2781 for regulator service parts				
	KK-4977 KIT	REGULATOR SERVICE KIT	1	1

## ACCESSORIES

### 85-469 CONVERSION TO DOUBLE REGULATOR ASSEMBLY KIT

Convert standard single regulator to a double regulator air control.

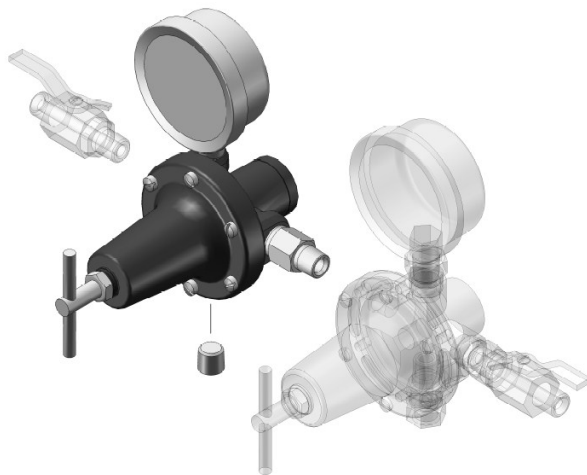

85-469 Double Regulator Conversion Kit

ITEM	PART NO.	DESCRIPTION	QTY
1	• -----	1/4 NPT PLUG (SUPPLIED W/ REGULATOR)	1
2	83-4233	D.M. NIPPLE 1/4 x 3/8	1
3	HAR-507	AIR REGULATOR	1
4	83-1355	GAUGE - 100 PSI	1
• Purchase locally			
	KK-4977 KIT	REGULATOR SERVICE KIT	1

## BOTTOM OUTLET KIT

### BOTTOM OUTLET KIT WITH LEGS

Allows conversion of tank from standard top outlet to bottom outlet.

All bottom outlet wetted parts are stainless steel.

**183-3000** for 2-gallon tanks with 3/4" bottom outlets

Includes three 183-3005 Leg Kits

**183-3001** for 10/15-gallon tanks with 3/4" bottom outlets

Includes three 183-3005 Leg Kits

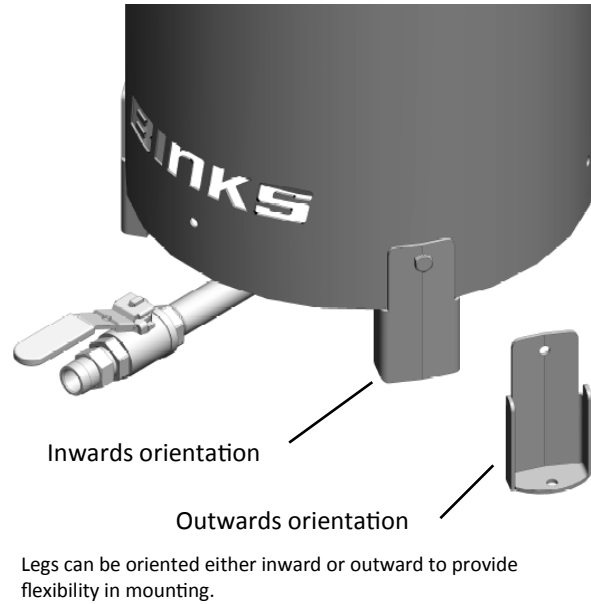
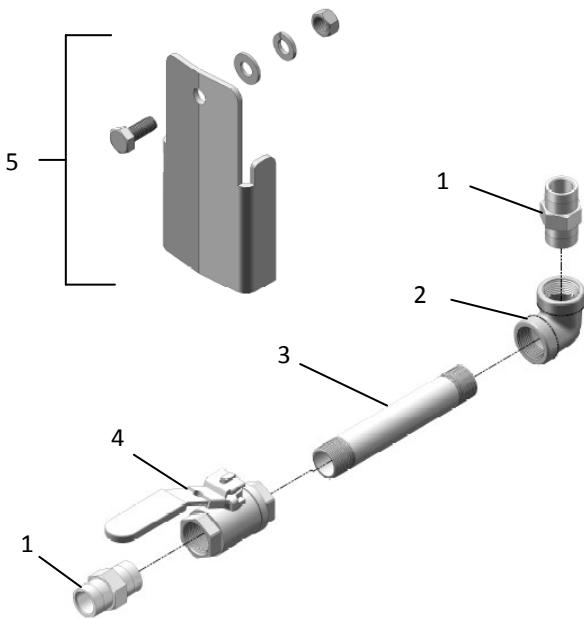

### 183-3000/1 Bottom Outlet Kit

ITEM	PART NO.	DESCRIPTION	QTY
1	-----	ADAPTER, 3/4 NPT-NPS UNIVERSAL	2
2	-----	ELBOW, 3/4 NPT (F)	1
3	-----	PIPE NIPPLE	1
4	-----	BALL VALVE, 3/4 NPT FULL PORT	1
5	183-3005	LEG KIT	3

**ITW Industrial Finishing:**

Ringwood Road, Bournemouth  
BH11 9LH England  
Tel: +44(0) 1202 571111 Fax: +44(0) 1202 573488  
Email: industrial.mktg@itwfinishing.co.uk

**ITW Oberflächentechnik GmbH:**

Justus-von-Liebig-Straße 31  
D-63128 Dietzenbach Germany  
Tel: +49 (0) 6074-403-1 Fax: +49 (0) 6074-403-300  
Email: marketing@itw-finishing.de

**U.S./Canada Technical Service Office:**

195 Internationale Blvd.  
Glendale Heights, IL 60139  
Toll-Free Telephone: 1-888-992-4657 (U.S.A. and Canada only)  
Toll-Free Fax: 1-888-246-5732

**Binks European Sales and Service Listing: [www.itwifeuro.com](http://www.itwifeuro.com)**